



PI6NMS

FINN-POWER PI 6NMS CRIMPING MACHINE FOR SERVICE LINE

## P16NMS – FAST, EASY AND COMPACT

This machine is a new, electric version of Powerco's classic PI 6 series. PI 6NMS is portable crimping machine which is designed for field service and on-site work. This service machine is easy and very comfortable to operate and it makes crimping faster and more efficient. PI 6NMS is highly reliable, simple and straight-forward to use.

This crimping machine is perfectly suitable for crimping smaller parts. PI 6NMS is also space-saving because of its compact size and design. PI 6NMS is also easy to carry from one location to another.

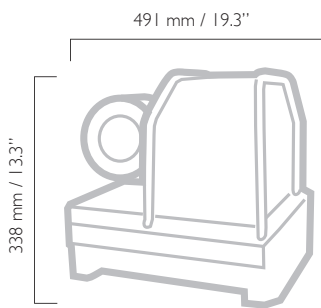

PI 6NMS



<http://powerco.lillbacka.com/products/service-line>

DIE SET TABLE P16

Pno	Crimp. range	D	L
18212/10	10.0 - 12.0	10	55
18212/12	12.0 - 14.0	12	55
18212/14	14.0 - 16.0	14	55
18212/16	16.0 - 19.0	16	55
18212/19	19.0 - 23.0	19	55
18212/23	23.0 - 27.0	23	55
18212/27	27.0 - 31.0	27	65
18212/31	31.0 - 38.0	31	65

PI 6NMS	
Crimping range (mm) <sup>1)</sup>	10-45
Crimping range (inch) <sup>1)</sup>	0.39-1.77
Max opening (mm)	+20
Max. crimping force (kN)	955
Max. crimping force (tonnage)	95
Motor (kW)	0,18
Motor (HP)	0,24
Weight (kg)	40
Weight (lbs)	88

1) With standard dies. Crimping range can be increased with special dies.